



ISSN: 2528-5688
E-ISSN: 2528-5696

VOLT

Jurnal Ilmiah Pendidikan Teknik Elektro

Journal homepage: jurnal.untirta.ac.id/index.php/VOLT

Vol. 3, No. 1, April 2018, 1 - 12



ROBOT CLASSIFYING OF GAS USING SUPPORT VECTOR MACHINE METHOD

Kgs. Moch Fachri^{1✉}, Nyayu Latifah Husni¹, Ekawati Prihatini¹

¹Department of Electrical Engineering

Politeknik Negeri Sriwijaya, Palembang 30139, Indonesia

✉Corresponding author e-mail: fachriarifin18@gmail.com

Received: August, 27th 2017. Received in revised form: October, 3rd 2017. Accepted: October, 20th 2017.

Available online: April, 1st 2018

Abstract

Fires often happen in the environment of industrial chemical plant caused by harmful gases. To minimize the incident that can be triggered by the gas it takes a tool capable of classifying gases are in the environment industry. The purpose of this research is to know the success in classifying gas on a fire that was triggered by the dangerous gases. We offer solutions in design and build a mobile robot that can classify objects contain hazardous gases by using the method of pattern recognition, the age of the SVM is still relatively young. Nevertheless, the advantages of SVM compared to another method lies in its ability to find the best hyperplane that separates the two class. Based on the results of testing data can classify SVM managed in accordance with the class. The degree of accuracy achieved SVM in classifying reached 86.66 %.

© 2018 Department of Electrical Engineering Education, UNTIRTA

Keywords: Support Vector Machine, Classification, Hyperplane, Sensor TGS

INTRODUCTION

Indonesia has quite a lot of industrial chemical plant is operating continuously. The fact that Indonesia is currently improving the quality of its production, with the possibility of the occurrence of the accidents that occur in the

company. The last few years, Indonesia was shocked by the large number of fires break out and damage to the environment caused by the release of harmful gases as a trigger. The circuit of electricity and gas in a factory environment risk will the occurrence of fires and other damage. Thus a company with a high level of risk

industrial plants need a tool that can give a warning and was able to classify the possibility of gas and another that can trigger the occurrence of such damage.

See the fact is, a lot of research on mobile robot which was successful in facilitating human work in the field of industry. As in investigating suspected hazardous areas to replace the role of humans (Redden, Pettitt, Carstens, & Elliott, 2008), detected objects (Pratama, Dewi, & Oktarina, 2017), measuring pH levels (Dinambar, Sari, & Irdayanti, 2017), transport the tub of trash (Oktarina, Nawawi, & Tulak, 2017). Some research on mobile robot in detecting gas at objects simulate different types of gases, such as octanol ethanol, trinitrotoluene, and tailored to the use of the gas sensor. Then do the development of mobile robot to detect the presence of gas with methods of intelligence (Loutfi, Coradeschi, Karlsson, & Broxvall, 2005), declaring the target gas (Li, Meng, Wang, & Zeng, 2010), localize the target gas (Lilienthal et al., 2004), and identifying the type of gas (Trincavelli & Loutfi, 2010).

But during the passage of time has not the discovery tool that is able to examine and classify gases are in the environmental industry to further ascertained whether the present is dangerous or not. Therefore, the required addition of method that is able to meet those needs through a method of Support Vector Machine (Byun & Lee, 2003). The methods that will be used in this research can identify patterns that are linear or non-linear.

In this research, there are 3 types of gas sensors are used, i.e. gas sensor TGS 2600, TGS 2602, and TGS 2620. Material detector gas sensors of metal oxide is a compound, in particular, SnO₂. TGS has a sensor the sensor prisoners whose value depends on the concentration of the oxygen reacts with the

Crystal metal oxide (SnO₂). TGS 2600 has a high sensitivity to low concentration gas contaminated air, such as hydrogen and carbon monoxide. This sensor can detect hydrogen at a rate of a few ppm. Pin configuration of the Sensor TGS can be seen in Figure 1.

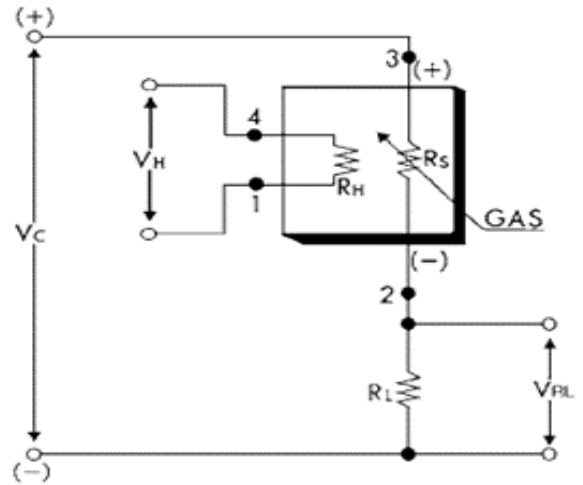

Figure 1. Pin configuration of the Sensor TGS

Sensing element of Gas Sensor TGS 2602 consists of a metal oxide semiconductor layer formed on alumina substrate of sensing chip in conjunction with an integrated heater. Sensor TGS 2602 has high sensitivity against gas smell with low concentration as ammonia and H₂S produced from household waste and office environment. Because of miniaturization against sensing chip, TGS 2602 only requires the flow heater of 42 mA and this device is built in the form of TO-5 package.

Sensor TGS 2620 have a high sensitivity towards organic aqueous steam additionally sensitive on flammable gases such as carbon dioxide or hydrogen. Refer to the sensor chip against a small, Sensor TGS 2620 only requires a current of 42 mA heater and stored in the package TO-5 standard. This sensor can detect some gases, namely gas methane, CO, isobutan, hydrogen and ethanol.

Support Vector Machine (SVM)

SVM is trying to find the best hyperplane in the input space. The basic principle of SVM linear classifier which is further developed in order to work on a non-linear problem by incorporating the concept of the kernel trick on high-dimensional workspace (Nugroho, Witarto, & Handoko, 2003). SVM can do separate classification data (linearly separable) linear and non-linear (separable non-linear). Linearly separable data is data that can be separated in linear. Suppose there is some hyperplane which separates positive and negative samples, then x in the hyperplane will satisfy the equation:

$$w \cdot x + b = 0 \tag{1}$$

For linear data problems, algorithms of support vector just look for the biggest margin hyperplane (the distance between the two classes of patterns). The best Hyperplane can not only separate the data properly but also that have the greatest margin. Data residing on the field delimiter is called support vector.

For solving non-linear data in the SVM is by way of mapping the data into a higher dimensional space (space features or feature space) (Borges, 1998), where data on these spaces can be separated in a linear, using the transformation of Φ at the following equation:

$$\phi : \mathbb{R}^d \rightarrow H \tag{2}$$

SVM was first developed by Vapniks for binary classification, but subsequently developed for multiclass classification (class). His approach is to build a multiclass classifier, namely by means of combining multiple SVM binary. This approach consists of One Against All and One Against One methods. Comparison of the method of support vector machine in various fields can be seen in table 1.

Table 1. Comparison of several methods of SVM.

Methods	Applied	Result	Reference
SVM-FUZZU	The Robot Identification of Gas	The accuracy of the SVM i.e. 98.84%.	(Rendyansyah, 2015)
SVM-NN	Prediction of graduation on Seed Potato Certification	The accuracy of the SVM i.e. 98,31%	(Suryadi, 2015)
SVM-MLP	The Banking Sector Stock Index Prediction	SVM has a very small error 2.71	(Hidayatullah, 2014)
SVM-RE	Analysis of Diagnosis of Breast Cancer Patients	The accuracy of the SVM of 94.34%	(F.A Novianti, 2012)

METHOD

The block diagram shown in Figure 2, it can be explained that the robot classifying gas has several important parts, including the parts of the input, output, control parts of the section, and the movers. At the input, the robot classifying gas works with incoming voltage supply comes from 1 piece battery 1000 MAh with 12V. Battery 1000 MAh will provide supplies to Motor Drivers. Motor Driver will drive the motor DC. Voltage supply before giving it to the Arduino Mega 2560, advance the voltage must be reduced to 5V through DC to DC Converter. The voltage should be downgraded

because of the incoming voltage from the Arduino Mega 2560 is 5V. Arduino Mega 2560 is used for processing and controlling the entire input system such as Ultrasonic Sensors, sensor TGS, and Compass sensor. The entire sensor supply voltage gets used from the Arduino Mega 2560.

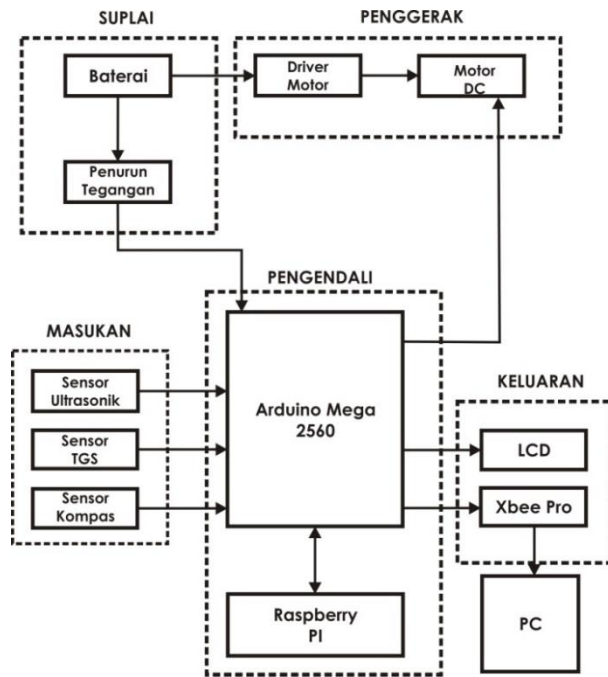

Figure 2. Diagram Block

On the controller, the robot uses gas classifying Arduino Mega 2560 and Raspberry PI 3 type B. Arduino Mega 2560 serves to control the sensors Ultrasonic Sensors, i.e. the Sensor TGS, and the compass sensor. While the Raspberry PI 3 type B serves to control the sensor TGS. Sensor TGS that used as many as 3 type, i.e. TGS, TGS 2602 2600, and TGS 2620. Sensor TGS is controlled by Raspberry PI 3 type B because of the methods used in classifying of gas method using Support Vector Machine (SVM). This method requires a large memory capacity. Raspberry PI 3 type B has a memory capacity of 1 GB. So used Raspberries PI 3 type B as controller of sensor TGS method using SVM.

In the output section, there are two components namely Xbee Pro LCD S2 and 16x2. Xbee Pro was the wireless serial interface function connect the microcontroller with one another through the medium of the air with a distance of this serial communications could reach 1.6 km outdoors. The main advantage of Xbee Pro selected as serial communications wireless because it has a low power consumption, i.e. 3.3 v. Xbee Pro used to transmit the results of the prediction made by robot classifying gases to the server. While the LCD is used as a display on a robot classifying gas.

In this research, there are 2 flowchart is used, among other things:

Flowchart of Robot Working System

In Figure 3 can be seen underneath the robot will start working when it detects the presence of gas.

When the robot detects a gas, the robot will start looking for the location of the source of the gas. Then after the presence of the gas was detected, then the robot will start classifying types of gas. There are 3 types of gas detected, i.e. ethanol, methanol and acetone.

Flowchart SVM can be seen in Figure 4, it can be seen that there are several stages of the completion of the SVM to the classification of gas.

Stages of training data capture is the process of gas concentration data retrieval. Training data retrieval is performed using gas sensors on the robot. In the data pengambilan, the sensor must be alive for 24 hours in order to get the appropriate value. The training data are taken to identify the pattern. It is this pattern that are used as training data.

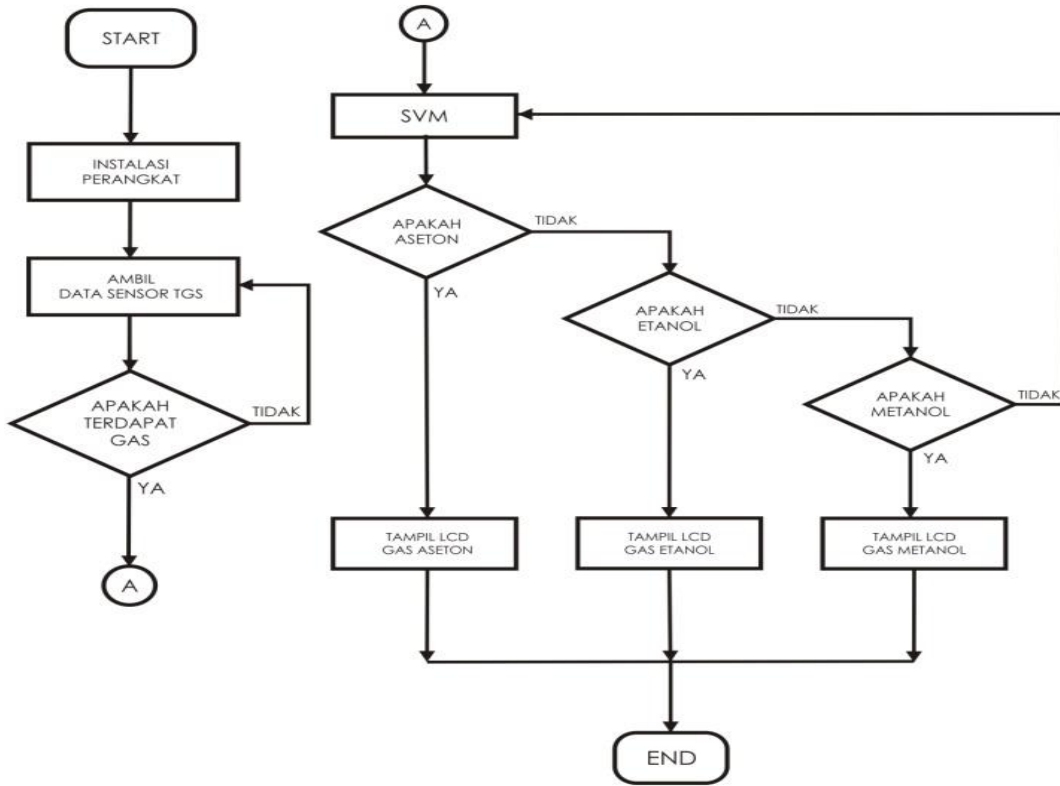

Figure 3. Robot Flowchart

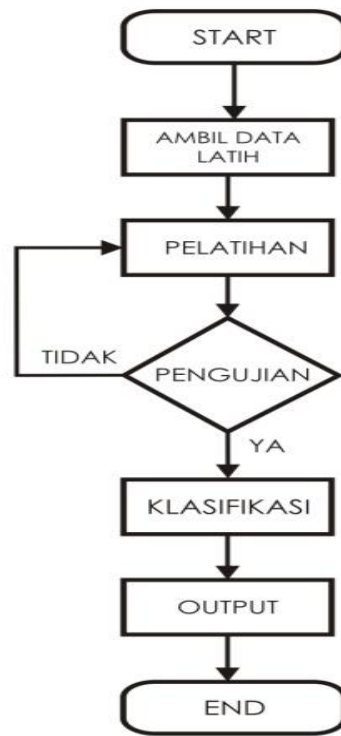

Figure 4. SVM Flowchart

At this stage of the training cases used SVM classification linearly. The function of the SVM is trying to find an optimal hyperplane. To define a hyperplane, use the formula:

$$W = \sum_{n=1}^{\infty} (a_i S_i) \quad (3)$$

Basically the process of SVM is divided into two stages, namely the process of training and testing process. On the training process, the variable hyperplane obtained will be saved. Then the data will be used as training data on the process of testing. In other words, the training process was to seek the support of vector data input.

After getting the results of the training process, then to know the performance of the system, performed the testing process. Testing conducted with the purpose of knowing the capabilities of SVM in classifying the gas. The process of testing the training results using the data to produce the correct classification of the test data. The end result of this process in the form of a value from a function the biggest decision that declares the class of the data is classified.

The result of the test process will appear on the lcd of the robot and sent to the server. The robot on the LCD will display the test results. We can also know the value of the concentration of the test results without having to monitor the robot in langusng. Xbee Pro equipped robot which Xbee Pro serve as devices that support wireless data communication (wireless). XBee Pro it will be connected to the PC. Then the PC will display information about the robots.

RESULT AND DISCUSSION

It has a mobile robot control using the arduino mega 2560 and raspberry PI. Arduino mega 2560 is connected with Ultrasonic sensors, sensors, compass, Xbee pro, and four DC motors,

whereas raspberry PI connects with sensor TGS and Ubec. In Figure 5 shows the mobile robot to be generated in this study.

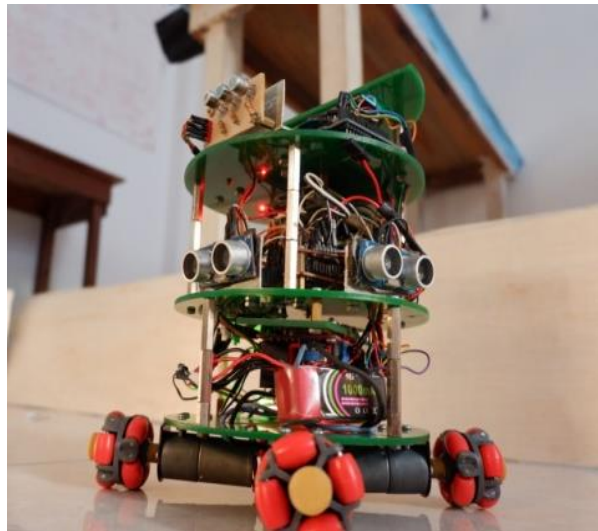

Figure 5. Mobile Robot

Gas sensors testing done in the room with the gas transporting acetone, ethanol, and methanol. Gas sensors are used namely 2602 2600 TGS, TGS, TGS and 2620. This testing is done with the purpose to know the form of the response or the output signal from the third type of gas sensors in detecting gas. How to test a gas sensor is shown in Figure 6.

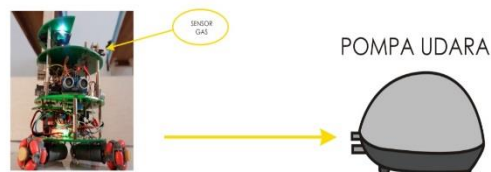
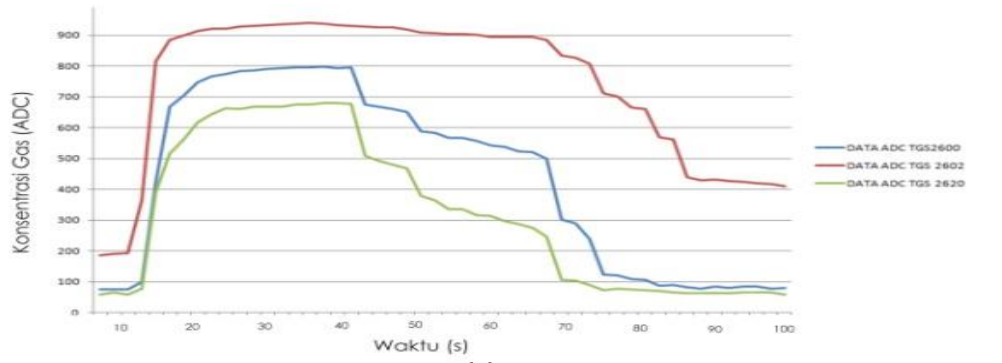
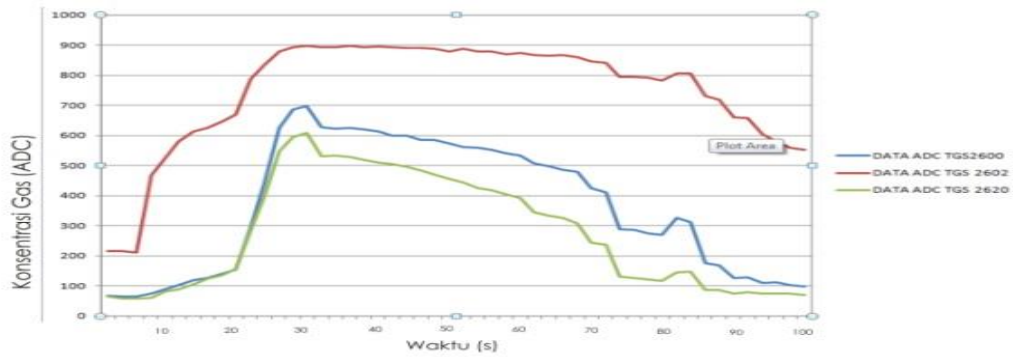

Figure 6. How to test a gas sensor

The gas is placed in front of the robot is 10 cm, 20 cm, 30 cm and 40 cm. Gas sensors testing done on a closed room. Evaporation of gas with the help of a pump which is directly geared to the robot. Testing done for 100s. Gas is directed to the robot using air pump for 20 seconds.



(a)



(b)

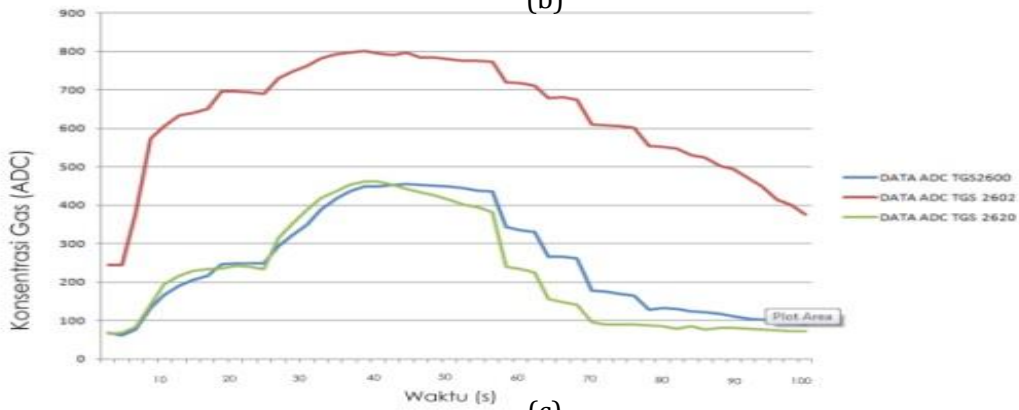

(c)

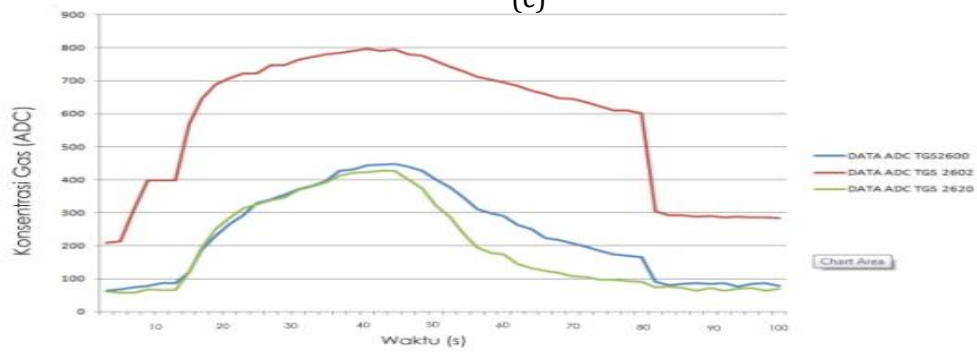

(d)

Figure 7. Results of testing the gas acetone, (a) distance of 10 cm, (b) distance of 20 cm, (c) distance of 30 cm (d) distance of 40 cm

Figure 7 shows the testing gas acetone. At a distance of 10 cm, the sensor has the highest gas concentration values i.e. 800 for TGS 2600, 920 for TGS 2602, and 680 for TGS 2620.

Figure 8 shows the testing of ethanol gas. At a distance of 10 cm, the sensor has the highest

gas concentration value i.e. 650 to 860 to 2600, TGS TGS 2602, and 540 to TGS 2620. Figure 9 shows the testing of ethanol gas. At a distance of 10 cm, the sensor has the highest gas concentration value i.e. 610 for TGS 2600, 770 for TGS 2602, and 520 for TGS 2620.

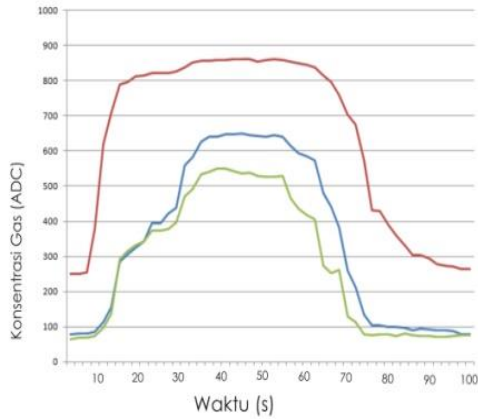

(a)

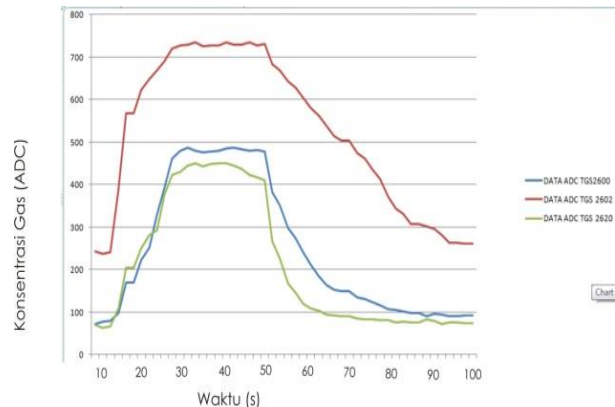

(b)

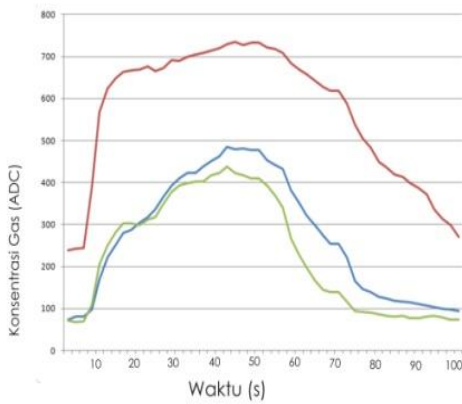

(c)

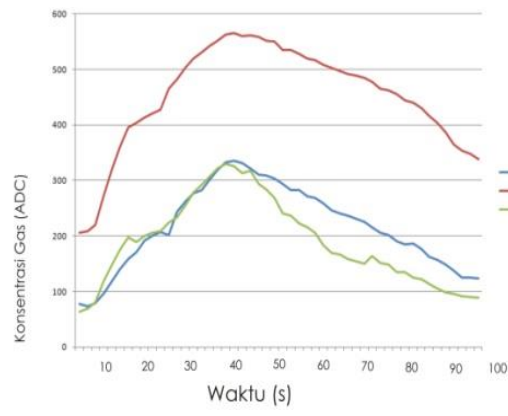

(d)

Figure 8. The test results of ethanol gas, (a) distance of 10 cm, (b) distance of 20 cm, (c) distance of 30 cm (d) the distance of 40 cm

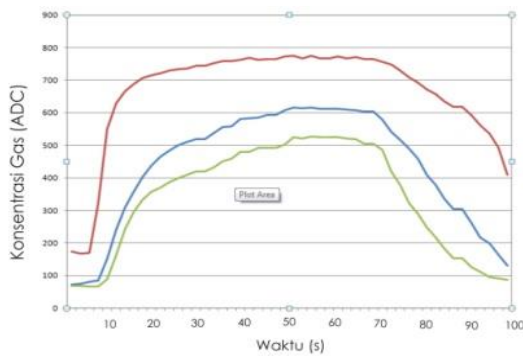

(a)

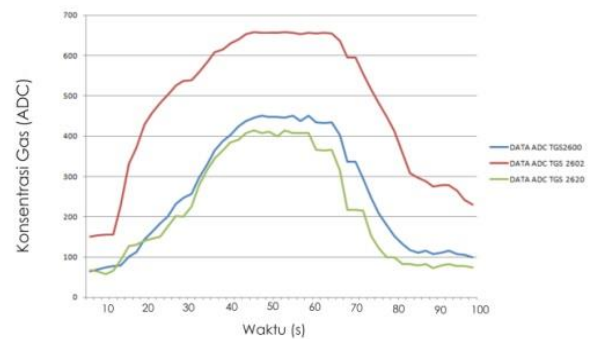

(b)

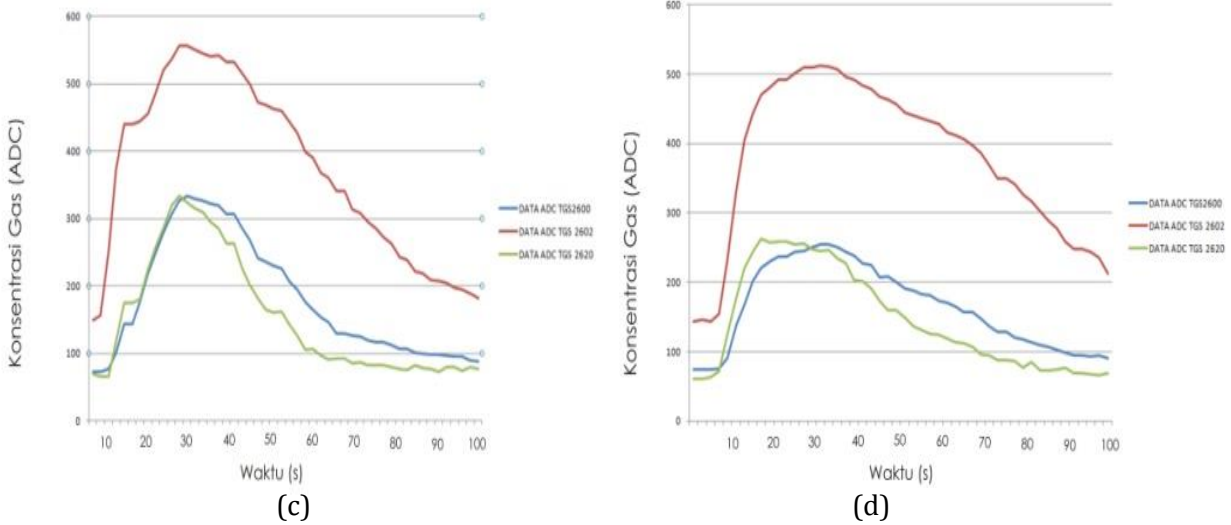

Figure 9. The test results of methanol gas, (a) distance of 10 cm, (b) distance of 20 cm, (c) distance of 30 cm (d) the distance of 40 cm

From the test results obtained that the three gas sensors can detect the gas acetone. Output of gas sensor response is converted to a form of Analog to Digital Converter, therefore these values illustrate the level of concentration of the gas. The higher the value of the ADC then the higher concentration.

It can be seen also on testing the gas acetone, ethanol, and methanol is that the value of the highest concentration of gas is at a distance of 10 cm. Distance between gas sensor with air pump has a great influence towards its concentration of gas. The closer the distance the gas acetone that was redirected to the gas sensor, then the higher the value of the concentration of gas sensor to read.

The process of classification can be translated with the effort to find the line (hyperplane) that separates the two groups. The two groups are groups of positive and negative groups. Positive classroom as + 1 while the negative class dinotasikan as -1.

Training data retrieval using three types of gas sensor TGS, i.e. TGS 2600, TGS 2602, and TGS 2620. On this test used three samples of gas

i.e. gas acetone, ethanol, and methanol. Training data generated on this test will be saved to be trained with SVM technique in testing phase. Figure 10 shows the results of the training data retrieval.

SVM testing was conducted to know the SVM prediction of SVM training data by using robots. As for the testing of SVM with simulation consists of the stages of training, stage of testing, and the test results with simulations.

After receiving the results of the training data, then conducted a training stage. This test aims to find out the capabilities of robots against training data generated this testing was done using the Net Beans version 8.

At this stage of the testing results of the training data are used to generate the correct classification of the training data. The end result of this phase in the form of predictions derived from SVM.

On testing the Robot Towards this type of Gas Samples performed as many as 18 times for gas, ethanol, acetone and methanol in turn. Testing conducted with a distance of 40 cm. Each gas carried out by as much as 6 times testing.

This testing is performed aiming to find out the capabilities of robots in classifying the gas. As for

the results of the testing robot in classifying the gases indicated on table 2.

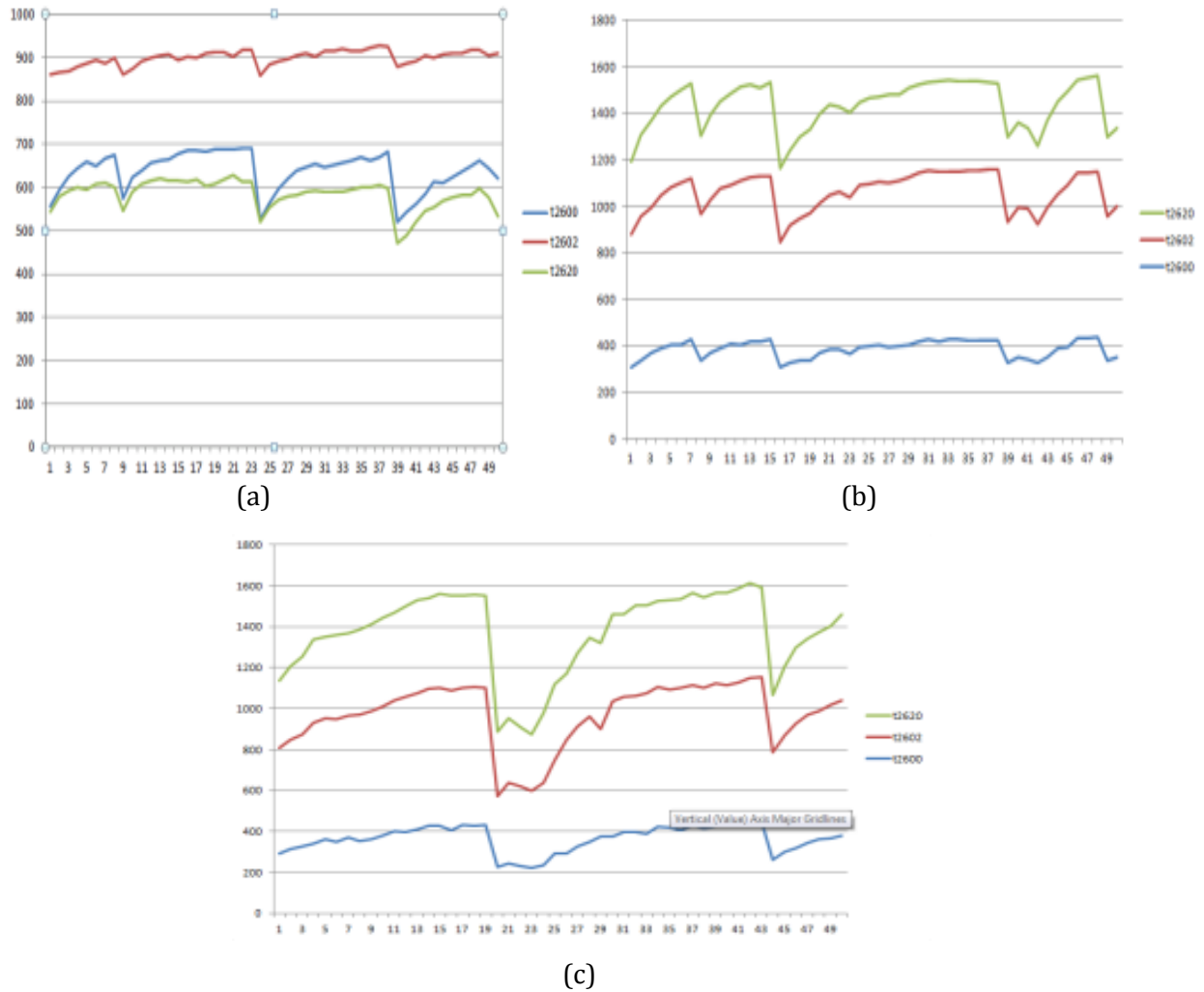

Figure 10. Training data (a) the Acetone Gas, (b) Ethanol Gas, (c) Methanol Gas

From 18 sample testing, mobile robots are having twice failed in classifying the gas. The accuracy achieved by SVM in classifying the gas is

$$x = \frac{\text{The number of successful testing}}{\text{The total number of tests}} \times 100\%$$

$$x = \frac{16}{18} \times 100\%$$

$$x = 86,66\%$$

Accuracy reached 86.66%. Based on these results, it can be said that the SVM manages to classify data in accordance with the class. The error that occurred in testing could happen because there is still the rest of other gases or gas before sticking on the sensor.

Table 2. The results of the testing robot in classifying gas

Testing	Test Gas	External Target	Description
1	Acetone	Acetone	Successfully
2	Acetone	Acetone	Successfully
3	Acetone	Acetone	Successfully
4	Acetone	Acetone	Successfully
5	Acetone	Acetone	Successfully
6	Acetone	Methanol	<i>Failed</i>
7	Ethanol	Ethanol	Successfully
8	Ethanol	Ethanol	Successfully
9	Ethanol	Methanol	<i>Failed</i>
10	Ethanol	Ethanol	Successfully
11	Ethanol	Ethanol	Successfully
12	Ethanol	Ethanol	Successfully
13	Methanol	Methanol	Successfully
14	Methanol	Methanol	Successfully
15	Methanol	Methanol	Successfully
16	Methanol	Methanol	Successfully
17	Methanol	Methanol	Successfully
18	Methanol	Methanol	Successfully

CONCLUSION

Based on the trial results and the analysis that has been done, it can be concluded that the test results show that SVM manages to classify data in accordance with the class. Of the 18 test samples, robots are having twice failed in classifying the gas. The degree of accuracy achieved SVM in classifying reached 86.66%.

REFERENCE

Burges, C. J. C. (1998). A Tutorial on Support Vector Machines for Pattern Recognition. *Data Mining and Knowledge Discovery*, 2(2), 121–167.

<https://doi.org/10.1023/A:1009715923555>

Byun, H., & Lee, S.-W. (2003). A survey on pattern recognition applications of support vector machines. *International Journal of Pattern Recognition and Artificial Intelligence*, 17(03), 459–486. <https://doi.org/10.1142/S0218001403002460>

Dinambar, B. P., Sari, D. P., & Irdyanti, Y. (2017). Analysis of The Measurement of PH Levels and Levels of Water Clarity on The Ship’s Robot. *VOLT: Jurnal Ilmiah Pendidikan Teknik Elektro*, 2(2), 133. <https://doi.org/10.30870/volt.v2i2.1929>

F.A Novianti, S. . P. (2012). Analisis Diagnosis Pasien Kanker Payudara Menggunakan Regresi Logistik dan Support Vector, 1(1).

Hidayatullah, T. (2014). Kajian Komparasi Penerapan Algoritma Support Vector Machine (SVM) dan Multilayer Perceptron (MLP) dalam Prediksi Indeks Saham Sektor Perbankan.

Li, J.-G., Meng, Q.-H., Wang, Y., & Zeng, M. (2010). Single odor source declaration in outdoor time-variant airflow environments. In *2010 IEEE International Conference on Robotics and Biomimetics* (pp. 143–148). IEEE. <https://doi.org/10.1109/ROBIO.2010.5723317>

Lilienthal, A., Ulmer, H., Frohlich, H., Stutzle, A., Werner, F., & Zell, A. (2004). Gas source declaration with a mobile robot. In *IEEE International Conference on Robotics and Automation, 2004. Proceedings. ICRA '04. 2004* (p. 1430–1435 Vol.2). IEEE. <https://doi.org/10.1109/ROBOT.2004.1308025>

Loutfi, A., Coradeschi, S., Karlsson, L., & Broxvall, M. (2005). Putting olfaction into action: using an electronic nose on a multi-sensing mobile robot. In *2004 IEEE/RSJ International Conference on Intelligent Robots and Systems (IROS) (IEEE Cat. No.04CH37566)* (Vol. 1, pp. 337–342). IEEE. <https://doi.org/10.1109/IROS.2004.1389374>

Nugroho, A. S., Witarto, A. B., & Handoko, D. (2003). *Support Vector Machine-Teori dan*

- Aplikasinya dalam Bioinformatika 1*. Retrieved from <http://asnugroho.net>
- Oktarina, Y., Nawawi, M., & Tulak, W. G. (2017). Analysis of The Sensor Line on Line Follower Robot as an Alternative Transport The Tub Trash in The Shopping Center. *VOLT: Jurnal Ilmiah Pendidikan Teknik Elektro*, 2(2), 101. <https://doi.org/10.30870/volt.v2i2.1859>
- Pratama, Y. W., Dewi, T., & Oktarina, Y. (2017). Analysis and Design of Obstacle Avoidance on Robot Detection of Pipe Cracked. *VOLT: Jurnal Ilmiah Pendidikan Teknik Elektro*, 2(2), 167. <https://doi.org/10.30870/volt.v2i2.2044>
- Redden, E. S., Pettitt, R. A., Carstens, C. B., & Elliott, L. R. (2008). Scalability of Robotic Displays: Display Size Investigation. Retrieved from <https://apps.dtic.mil/docs/citations/ADA481586>
- Rendyansyah. (2015). Implementasi Kendali Logika Fuzzy dan Pengenalan Pola Support Vector Machine Pada Olfactory Arm Mobile Robot untuk Identifikasi Gas.
- Suryadi, U. T. (2015). Komparasi Support Vector Machine dan Neural Network untuk Prediksi Kelulusan Sertifikasi Benih Kentang. *Seminar Nasional Informatika (SEMNASIF)*, 1(1). Retrieved from <http://jurnal.upnyk.ac.id/index.php/semnasif/article/view/1397>
- Trincavelli, M., & Loutfi, A. (2010). Feature selection for gas identification with a mobile robot. In *2010 IEEE International Conference on Robotics and Automation* (pp. 2852–2857). IEEE. <https://doi.org/10.1109/ROBOT.2010.5509617>