

## Utilization of the Hall Effect to Detect Leakage Current in DC System Branch Loads Using the Positive-Negative Current Difference Method

Ahmad Ilham Kamal<sup>1</sup>, Nur Rahma Dona<sup>1</sup>

<sup>1</sup>Guohua Taidian Pembangkitan Jawa Bali Co., Ltd, O&M Java  
7 USC CFPP, Serang, Banten, Indonesia

### Informasi Artikel

Naskah Diterima : 29 Februari  
2024

Direvisi : 29 Mei 2024

Disetujui : 31 Mei 2024

\*Korespondensi Penulis :  
ahmadilham.kamal@gmail.com

### Graphical abstract

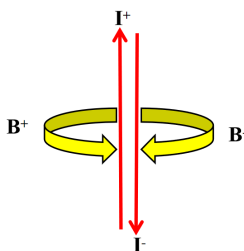

### Abstract

Currently, many industries use DC power as a power supply for controller equipment, etc. All companies want their DC system to be reliable. One effort to maintain the reliability of the DC system is to monitor the leakage current in each branch of the DC system load. Leakage currents that occur if not discovered early on will gradually result in short circuit currents and instability of the DC system. This research wants to use the hall effect to detect leakage currents in branch loads using the difference in current in the positive (+) and negative (-) cables. Use the right-hand law for the direction of the magnetic field. Insert the positive (+) and negative (-) cables into the same Hall sensor where the resultant magnetic field will be 0 under normal circumstances and  $>0$  or  $<0$  if there is a leakage current in one of the cables. Because of this, the Hall effect can be used to detect leakage currents (Ground Fault) in DC systems. Another advantage of the Hall effect is that it monitors DC system leakage currents continuously while operating.

**Keywords:** Hall, Effect, DC, Resultant, Current.

### Abstrak

Pada saat ini banyak industri yang menggunakan daya DC sebagai suplai daya untuk peralatan controller dsb. semua perusahaan pasti menginginkan sistem DC-nya handal salah satu upaya menjaga ke-handalan sistem DC adalah memantau arus bocor di tiap cabang beban DC system. Arus bocor yang terjadi jika tidak diketahui sejak dini lambat laun akan mengakibatkan arus hubung singkat dan mengakibatkan ketidakstabilan DC system. Penelitian kali ini ingin mengaplikasikan penggunaan hall effect untuk pendeteksian arus bocor pada beban cabang menggunakan perbedaan arus pada kabel positif (+) dan negatif (-). menggunakan hukum tangan kanan untuk arah medan magnet. memasukkan kabel positif (+) dan negatif (-) ke dalam hall sensor yang sama yang nantinya jumlah resultant medan magnet-nya akan bernilai 0 dalam keadaan normal dan  $>0$  atau  $<0$  jika ada arus bocor di salah satu kabel. Oleh karena efek hall dapat digunakan dalam pendeteksian arus bocor (Ground Fault) pada sistem DC, dan keunggulan yang lain adalah efek hall juga dapat memonitor arus bocor sistem DC secara kontinu pada saat sistem beroperasi.

**Kata kunci:** Hall, Effect, DC, Resultan, Arus.

© 2024 Penerbit Jurusan Teknik Elektro UNTIRTA Press. All rights reserved

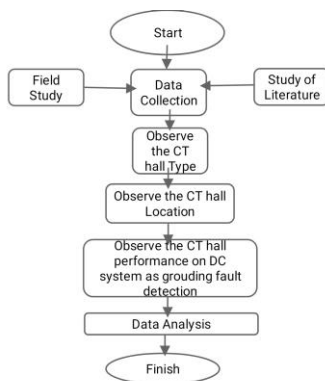

## 1. INTRODUCTION

The DC system is vital in almost all industries; in the power generation industry, the DC supply is used for various purposes. Usually, in the power generation industry, the DC system is divided into two types, namely the 110VDC system and the 220VDC system, where for the 110VDC system, the supply is used for relay equipment. Protection, automation devices, and control circuits for various systems, while the 220 VDC system is used for UPS supply backup and motor lubricant oil backup. More research is needed to discuss the use of the Hall effect for detecting leakage currents. However,

there is research on the Hall effect for detecting leakage currents; it focuses more on device prototypes and needs to explain in detail the essential workings of the device.

Currently there are methods for detecting ground faults in DC systems. Traditional methods, such as the AC signal injection method, are unreliable, which results in ripple voltage in the system and can cause interference in the load branch equipment. Another traditional method is the balanced resistance method. This method is less effective because it can detect leakage current but is not specific to the load branch, which can only detect one system. Another traditional method is DC signal injection. This method is only carried out when a leakage current has occurred, cannot be monitored continuously, and is corrective [1]. Utilization the Hall effect in this research, the author wants to explain the essential workings and advantages of a leakage current detection device. The DC system scheme for the power plant is as follows: Figure 1.

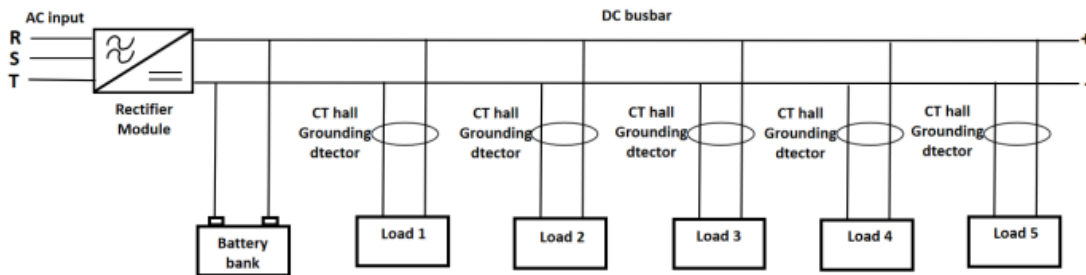

Figure 1. DC system in power plant

The current measuring device in a DC system is more complex than in an AC system. In an AC system, it can only be done with a CT (current transformer) in the form of a series of inductors that are wound around an iron core and will be induced by a magnetic field whose direction changes over time. We can see from the Faraday induction formula that a potential difference will be generated due to changes in magnetic flux with time in Equation (1).

$$\varepsilon = -N \frac{\Delta \Phi}{\Delta t} \tag{1}$$

with  $\varepsilon$  being emf induction (V),  $N$  is the number of turns, and  $\frac{\Delta \Phi}{\Delta t}$  being the rate of magnetic flux change (Wb/s).

From the Faraday formula, we can conclude that in an AC system, the secondary side of the CT (current transformer) can generate an electric force because the AC current takes the form of a sinusoidal wave concerning time. It also causes the magnetic flux to take a sinusoidal shape over time [2]. Meanwhile, in a DC system, the magnetic flux does not change with time if we put it into the Faraday formula in Equation (2).

$$\varepsilon = -N \frac{\Delta \Phi}{\Delta t} = -N \cdot 0 = 0 \tag{2}$$

Ordinary CT cannot be used as a sensor to measure current in a DC system; therefore, there are other methods for measuring current in a DC system. The first method is to use a diverter or resistor with a fixed value, which is known; then, the potential difference between the two ends of the resistor is representative of the current value because it refers to Ohm's law formula in Equation (3).

$$V = I \cdot R, \quad V \uparrow = I \uparrow \cdot R \tag{3}$$



From the ohm formula, it can be seen that if R remains constant and the current increases, the voltage also increases [3]. The circuit description using a diverter as a current measuring device is as follows in Figure 2.

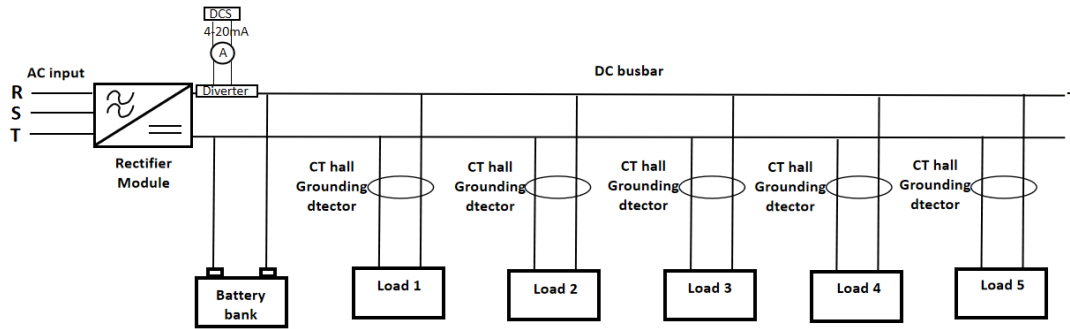

Figure 2. Diverter installation in the DC system

The potential difference at both ends of the diverter will enter the transducer, and the transducer will process the potential difference into a 4-20mA signal current to the DCS (distributed control system). The second way to measure current in a DC system is to use a hall sensor, namely the hall effect, to measure DC. In this paper, the hall effect is applied not only to measure DC but also to detect leakage current (ground fault) in the feeder (load).

## 2. RESEARCH METHOD

### 2.1 Hall Effect

The Hall effect is a phenomenon proposed by an American physicist named Edwin Hall. This phenomenon occurs when a conductor plate is electrified by DC electricity and exposed to a magnetic field perpendicular to it. There will be a potential difference at the ends of the conductor that is perpendicular to the direction of the electric current; this occurs because of the Lorentz force from the magnetic field, which deflects the electron charge and the existing electric current [4].

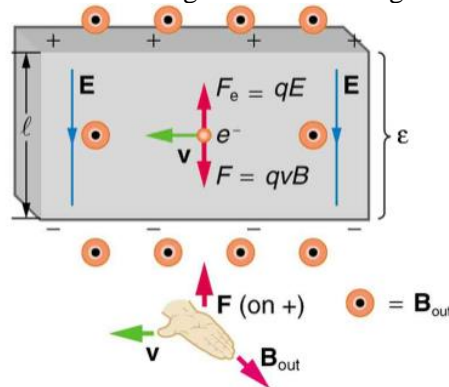

Figure 3. Description of the Lorentz force in the hall effect phenomenon (B) direction of the magnetic field approaching the screen (F) direction of the Lorentz Force (v) speed in the direction of the electric flow (l) width of the conductor plate (E) potential difference due to the hall effect.

The potential difference value can be obtained from the following Equation (4).

$$\varepsilon = B \cdot l \cdot v \quad (4)$$

The magnetic field generated by the surrounding electrical conductor is not large, therefore a concentrator is needed to strengthen the magnetic field so that the Hall effect generated is more significant [5].

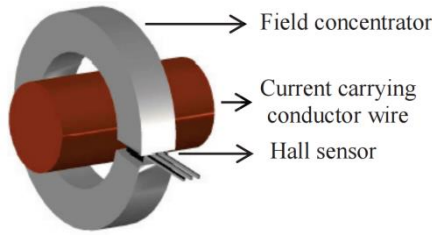

Figure 4. Design of magnetic field concentrator

The methodology used in writing this paper is literature studies from journals. Because there are not many studies discussing the use of the Hall effect for grounding detection in DC systems, the author also uses sources from manual books for DC power generation systems and wiring diagrams for DC systems in power plants, as well as observations of DC power plant system equipment, especially hall CTs for detecting leakage currents (ground faults). The research flow diagram is as follows in figure 5:

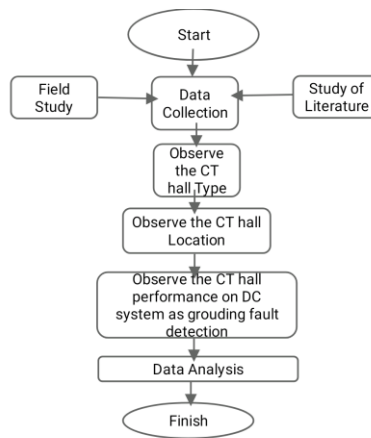

Figure 5. The research flow diagram

### 3. RESULT AND DISCUSSIONS

Apart from being used as a current measuring device in DC systems, the Hall effect can also be used as a ground fault detector in DC systems by utilizing the resultant magnetic field produced by positive (+) and negative (-) cables. If, under normal circumstances, the current in the positive (+) and negative (-) conductor cables is the same, then the resultant magnetic field density value is 0. It is based on the right-hand rule magnetic field density formula:

$$\Sigma \vec{B} = \left( \frac{I^+ \cdot \mu_0}{2\pi \cdot r} \right) + \left( \frac{I^- \cdot \mu_0}{2\pi \cdot r} \right) \tag{5}$$

with  $\Sigma$  is Resultant magnetic field,  $I^+$ ,  $I^-$  are electric currents in the positive and negative cables, and  $\mu_0$  is the vacuum permeability value.

The description of the direction of the electric current and the direction of the magnetic field in the introductory cable is as follows in Figure 6.



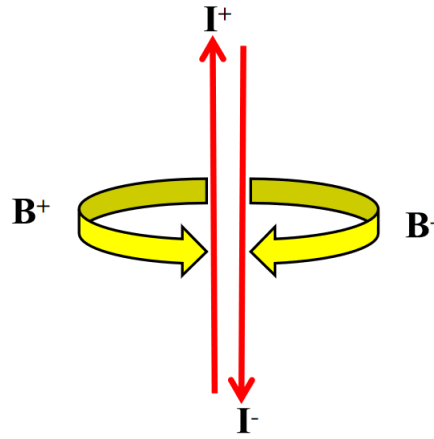

Figure 6. Overview of the direction of electric current and magnetic field in positive (+) and negative (-) cables

$I^+$  and  $I^-$  are electric currents in the positive and negative cables, and  $B^+$ ,  $B^-$ , and magnetic fields in the positive and negative cables [6].

Hall CT design overview for leakage current detector follows in Figure 7.

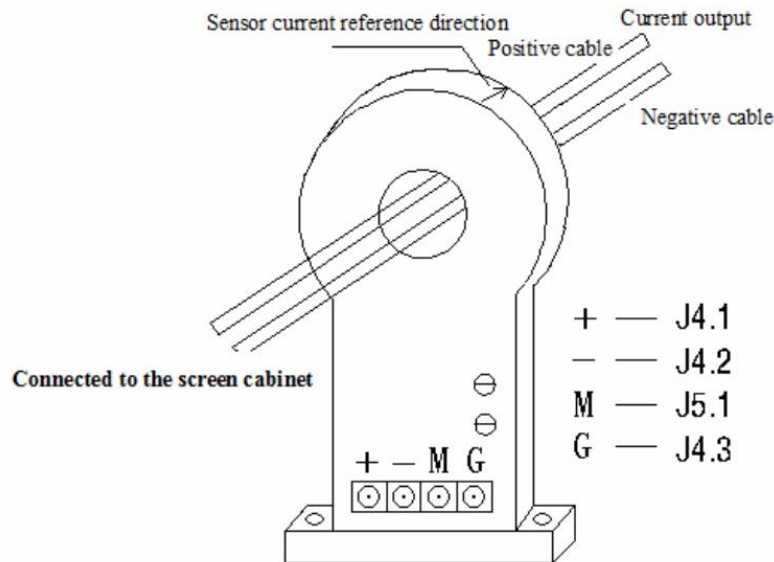

Figure 7. Hall CT design for leakage current detector (ground fault)

From the Lorentz force potential difference formula in Equation (4), we can enter the resultant magnetic field density in Equation (5) and then in Equation (6).

$$\varepsilon = B \cdot \ell \cdot v = \sum \vec{B} \cdot \ell \cdot v = \left( \frac{I^+ \cdot \mu_0}{2\pi \cdot r} \right) + \left( \frac{I^- \cdot \mu_0}{2\pi \cdot r} \right) \cdot \ell \cdot v \tag{6}$$

From Equation (6), we see that all variables are constant except for the variable electric current in the positive (+) and negative (-) cables. Under normal circumstances, a load on a DC system, the current in the positive (+) and negative (-) carriers will be the same, based on the Kirchoff II Equation (7).

$$\sum \varepsilon + \sum IR = 0 \tag{7}$$

Where the algebraic sum of the emf in each closed loop (load branch) with a voltage drop is equal to 0 because the load relationship with the voltage source in the generator DC system is parallel,



each load branch has its own loop, and the current in each load branch is different. According to the resistance value of each load, the current value in the positive (+) and negative (-) cables in each load branch is the same under normal circumstances.

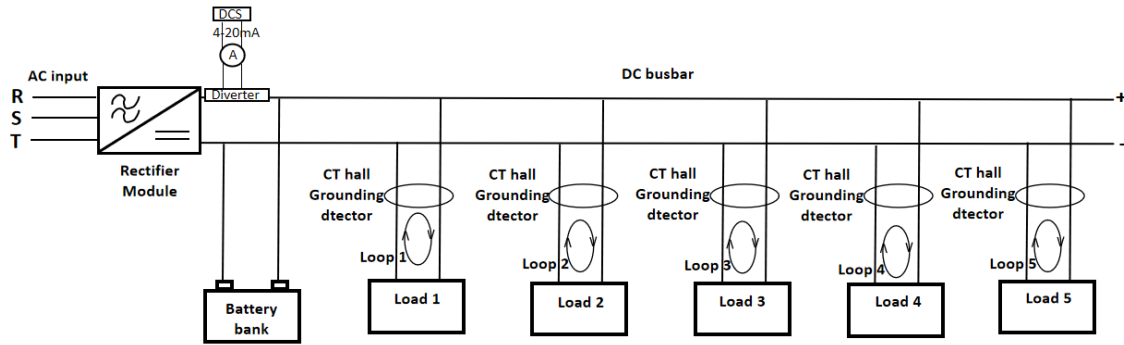

Figure 8. Closed loop in each branch load

From Equation (6) and also Kirchoff's law II Equation (7), we can find that if, under normal circumstances, there is no leakage current (ground fault), then the current value in the positive (+) and negative (-) conductor cables is the same and if the value If the current is the same, the resultant magnetic field density will be 0, and this will result in the Lorentz force acting on the electrified sensor introduction plate being 0 and resulting in a voltage difference due to the Hall effect being 0.

$$\begin{aligned} \varepsilon &= B \cdot \ell \cdot v = \sum \vec{B} \cdot \ell \cdot v = \left( \frac{I^+ \cdot \mu_0}{2\pi \cdot r} \right) + \left( \frac{I^- \cdot \mu_0}{2\pi \cdot r} \right) \cdot \ell \cdot v \\ &= (0) \cdot \ell \cdot v \\ \varepsilon &= 0 \end{aligned} \tag{8}$$

Suppose the branch load has a leakage current (ground fault). In that case, it will cause the current values in the positive (+) and negative (-) carriers to be different, giving rise to a resultant magnetic field that is not equal to 0. A Lorentz force is acting on the sensor lead plate that is supplied with electricity. Electricity has a value and causes the sensor plate to have a potential difference at the ends, perpendicular to the direction of the electric current on the plate, because of the hall effect. The voltage difference value shows the load branch's leakage current (ground fault).

#### 4. CONCLUSION

There are several methods for detecting leakage current in DC systems. Traditional methods, such as the AC signal injection method, are unreliable, which results in ripple voltage in the system and can cause interference in the load branch equipment. Another traditional method is the balanced resistance method. This method is less effective because it can detect leakage current but is not specific to the load branch, which can only detect one system. Another traditional method is DC signal injection. This method is only carried out when a leakage current has occurred, cannot be monitored continuously, and is corrective.

The Hall effect has many uses. It can also be used to measure electric current in DC systems and to detect leakage current (ground fault). Furthermore, this method is the most efficient, effective, and reliable because the method works continuously as long as the system is working and does not interfere with the performance of the equipment on each branch load. It can also identify specific points of disturbance locations on branch loads.

## REFERENCES

- [1] Anantha Krishna, M. S., & Srinivasan, A. D. (2019). Detection of DC Ground Faults of Ungrounded DC System in Sub-Stations/Power Plants. *International Journal of Recent Technology and Engineering (IJRTE)*. ISSN: 2277–3878 (Online), Volume-8, Issue-1, May 2019, pp. 2101–2106.
- [2] Kinsler, Paul. (2020). "Faraday's Law and Magnetic Induction: Cause and Effect, Experiment and Theory"; *Physics* 2, no. 2: 150-163. <https://doi.org/10.3390/physics2020009>
- [3] Zubair, Abdul Rasak. (2020, November). Basic Concepts and Ohm's Law. In book: *Towards Understanding and Expertise in Applied Electricity: (Part 1) Fundamentals of Electrical and Electronic Engineering made simple (pp.1-16)* Publisher: LAP LAMBERT Academic Publishing.
- [4] M Creff, F Faisant, J M Rubi, Jean-Eric Wegrowe. (2020). Surface currents in Hall devices. *Journal of Applied Physics*, 128, ff10.1063/5.0013182ff. ffhal-02936737f
- [5] Dewi, S. D. T., Panatarani, C., & Joni, I. (2016, February). Design and development of DC high current sensor using Hall-Effect method. In *AIP Conference Proceedings (Vol. 1712, No. 1)*. AIP Publishing. <https://doi.org/10.1063/1.4941871>
- [6] "Leakage Current Measurement Sampling Sensor," in *JZ-MC-V Type Multi-Function Monitoring and Control Device Operation Instruction*, Harbin: Harbin Jiuzhou Electric Co., Ltd. 2014, pp. 47-48.

