

## Is There a Relationship Between Social Capital and Organizational Citizenship Behavior?: An Empirical Study from Legislature Member

Khairul Amri<sup>1</sup>, Nurmala<sup>2</sup>

<sup>1</sup>Fakultas Ekonomi dan Bisnis Islam, Universitas Islam Negeri Ar-raniry, Banda Aceh.

<sup>2</sup>Fakultas Ekonomi dan Bisnis, Universitas Muhammadiyah, Banda Aceh

### Abstract

*Social capital is very important for every individual including members of the legislature. Theoretically and referring to the findings of previous studies organizational citizenship behavior is positively related to the social capital. Until now no studies have examined the relationship between social capital and organizational citizenship behavior on legislature. This paper presents the empirical findings on the relationship between social capitals with organizational citizenship behavior among legislature member in the Aceh province of Indonesia. The samples of the study are 243 legislature members from 23 districts in Aceh Province. The data collection utilizes questionnaires. We employed structural equation modeling for the research framework and AMOS was used to analyze the model. Our study reveals that social capital significantly related to organizational citizenship behavior.*

**Keywords:** *Organizational Citizenship Behavior; Social Capital; Structural Equation Modeling*

### Abstrak

*Modal sosial sangat penting bagi setiap individu termasuk anggota legislatif. Secara teoritis dan mengacu kepada temuan penelitian sebelumnya, perilaku warga organisasi (OCB) berhubungan positif dengan modal sosial. Sampai saat ini belum ada penelitian yang meneliti hubungan antara modal sosial dan perilaku warga organisasi (OCB) pada lembaga legislatif. Penelitian ini menyajikan temuan empiris tentang hubungan antara modal sosial dengan perilaku warga organisasi (OCB) di kalangan anggota legislatif di Propinsi Aceh, Indonesia. Sampel penelitian berjumlah 243 anggota legislatif dari 23 kabupaten di provinsi Aceh. Pengumpulan data menggunakan kuesioner. Kami menggunakan pemodelan persamaan struktural untuk kerangka penelitian dan AMOS digunakan untuk menganalisis model. Penelitian ini mengungkapkan bahwa modal sosial secara signifikan terkait dengan perilaku kewargaan organisasional.*

**Kata Kunci:** *Perilaku warga organisasi; Modal Sosial; Model Persamaan Struktur*

Korespondensi: [khairul.amri@ar-raniry.ac.id](mailto:khairul.amri@ar-raniry.ac.id)

**Submitted:** 1 Juli 2021, **Revised:** 1 Oktober 2021, **Published:** 31 Desember 2021

## INTRODUCTION

Theoretically, organizational citizenship behavior (whereby, “OCB”) that exist in a person associated with social capital owned by the person. That is, social capital becomes one of the determining factors organizational citizenship behaviors. This is certainly very reasonable because the OCB is basically concerned with the behavior of people in the organization where they work. OCB a person is usually manifested in the form of empathy, mutual help and willingness to provide the best for the organization of employment (Ratnawati & Amri, 2013). All of these indicators, associated with social capital owned by someone.

For legislators of the city/district area, social capital is the main asset in the task as representatives of the people in the area. Moreover, in accordance with their mandate, members of parliament have three function which consist of legislative function, budgetary and supervisory functions. In this case, social capital embodied in the form of their mutual trust among members of parliament, confidence in the government as well as aligning the interests of society as their constituents with the wishes of the local government as an executive. Therefore, the task as legislators also need their OCB. OCB can be defined as the helpful attitude shown by members of the organization, that are constructive, valued by the organization but not directly related to individual productivity (Aldag & Resckhe, 2007). OCB or extra role behavior is the contribution of workers over and over formal job description (Randall, 2000).

In this context, the behavior of legislators in districts and cities in Aceh is relatively different among them. That is, people have different relative assessment of the behavior of legislators in their area. Poor understanding of the legislative members of the legislation have an impact on the obstacles they faced in exercising legislative, budgeting and monitoring functions. In addition, some members of the public also complained about the attitude and behavior of legislators who do not seem in favor of their interests, but more likely concerned with the interest groups and parties.

The members of parliament of the district in the province of Aceh have diverse OCB. Hence, social capitals which are possessed by them are relatively diverse. It is due to the close relationship between OCB and social capital which are interesting to be investigated. In addition, the members of the parliament who assume the

representative roles and functions of the people should be able to expose emphatic, simphatic attitude and the attitude of helping each other. In addition, social capital which can be indicated with the ability to socialize with the society and environment within their legislative workplaces become a crucial need for each of the member of the parliament.

The study on the relationship between social capital and organizational citizenship behavior still results in paradox conclusions. Shahi et al. (2013), Yazdanpanah & Pordal (2014) found out that social capital is directly and significantly related to the OCB. Similarly, research findings Amintojar et al. (2015) concluded that OCB is related to social capital. Otherwise, empirical study conducted by Abdollahi & Gorji (2014) reveal the empirical evidence indicating there is no relationship between the two variables. Refer to these studies, there is no consistent conclusion in the linkages between social capital and organizational citizenship behavior. This study seeks to confirm the relationship between the two variables with the study focusing on the subject of research are legislators in the Aceh province Indonesia. Election of members of parliament as a research subject based on the premise that a study of social capital and organizational citizenship behavior on the legislators have not been done by previous researchers.

## **LITERATURE REVIEWS**

### **Social capital**

One of the mostly concept in social science is social capital (Pierce, Lovrich & Budd, 2016). Social capital can be defined as the characteristics of social organization is likely confidence, value and norms leading to the organization's efficiency and effectiveness (Putnam, 1993:167). According to Nahapiet and Ghoshal (1989) social capital have three dimensions, namely cognitive, relational and stuctural dimension. All the dimensions is related to the interactional pattern of the people in a organization (Moghimi, 2010). The structural dimensions of the social capital refers to the connectional pattern of the organization members indicating the characteristics of their network. In other word, the dimension are specially described as the connectivity of the people, and how to invididual connect to each others.

Unlike the structural dimension, the relational dimension of social capital is related to the quality of interpersonal relationship in the organization. The dimension consist of commitments, trust, norms and identity. Selanjutnya, the cognitive dimension explore the extent of shared value among the individuals through shared codes and language and exchange of the stories of their background (Moghimi, 2010).

### **Organizational citizenship behavior**

Organization citizenship behavior (OCB) is a work behavior that exceeds the basic needs of a worker (Jahangir, Akbar, &Haq, 2004). Organ, Podsakoff, and MacKenzie (2006) state that is the freedom of individual behavior, which is indirectly or explicitly acknowledged by the reward system, and contributes to the effectiveness and efficiency of organizational functions. OCB can also be seen as behaviors and attitudes that benefit organizations. Examples include help with co-workers to ease their workload, not much rest, and help others to solve their problem in the workplace. The OCB has a significant contribution on the development of the organization in the future (Organ et al., 1995).

In general, OCB refers to behaviors that are not part of a formal employee job description (eg, helping co-workers, being polite to others), or employee behavior is formally uncompensated (Jex, 2002). Bogler and Somech (2005) emphasize that OCB is a behavior directed by the individual or the organization as a whole. Refer to the definitions can be concluded that OCB is a voluntary behavior that exceeds the basic needs of workers such as helping colleagues and being polite to others, which benefits the organization and is not directly related to the compensation system.

### **The link between social capitaland organizational citizenship behavior**

Balino, Turnley, & Bloodgod (2002) reveal that OCB leads to the existence of three forms of social capital consist of structural, relational and cognitive forms. Citizenship behavior not only influences on social capital, but also it is positively impact on individual performance (Sabatini, 2008). Baghersalimi et al. (2011) also reveals that OCB positively and significantly correlated to social capital. Empirical findings related to the relationship between social capital and OCB was also expressed

by some previous researchers. Shahi et al. (2013) reveals that the social capital dimensions are significantly related to OCB.

The study's findings are consistent with research findings by Yazdanpanah & Pordal (2014), Archana & Unni (2014) which concluded that all the dimensions of the variable is directly associated with OCB. Similarly, research finding of Amintojjar et al. (2015) about the influence of social capital on employee's OCB who take on cases in Mashad Municipality also found that OCB is directly related to social capital. The study conducted by Ahmadpoor et al. (2014) concludes that empirical evidence that OCB is significantly related to social capital. Similar to the conclusions, Ariani (2012) discovers that OCB is not only related to social capital, but also positively impact on the performance of organization's members.

### **Research hypotheses**

The present study seeks to determine the relationship between social capital and organizational citizenship behavior for legislative member in Aceh Province Indonesia. To do so, the following is the hypothesis of the study "There is a meaningful relationship between the elements of social capital and organizational citizenship behavior for legislative member in Aceh Province Indonesia

## **RESEARCH METHODS**

The study population was all members of Parliament in the province totaling 728 people composed of 81 legislators from municipalities/districts and 647 legislators from Aceh province. The research samples of 243 people, or 30 percent of the total population. Sampling was done by proportional sampling in all of Parliament both the provincial and city district levels. Determining a person's legislators for the research sample is based on the following criteria: (1) it has been a member of parliament of more than one period, and (2) each of the member willing to be a research sample.

The data collection utilizes questionnaires. The questionnaire related to social capital described in 9 items of statement developed in three dimensions of social capital including structures, cognition and communication. The questions were adopted from Nahapiet and Ghosal (1998). Furthermore, the questionnaires related

to organizational citizenship behavior (OCB) consists of six questions that adopts of Piercy et al. (2002). Both of statements related to social capital and organizational citizenship behavior give alternative answers which indicate the level form of agreement (Amri, 2013; Iskandar & Amri, 2013). The scale of measurement used in this study is the Likert scale with interval 1-5. Scoring is intended to give scores to each alternative level of agreement with the provisions score 1 = strongly disagree, 2 = disagree, 3 = neutral, 4 = agree and 5 = strongly agree (Farnita&Amri, 2013;Amri, 2015).

Furthermore, the analysis model used is the structural equation model (SEM) which is operated with AMOS software version 21. For the SEM there are several criteria regarding the goodness of fit index and the cut-off-value to test whether a model can be accepted or rejected (Ghozali, 2011). The criteria is consist of Chi-Square, Probability, RMSEA, GFI, AGFI, TLI, and CFI. The main criteria of the index are  $\chi^2$  test > X table; GFI > .90; AGFI > .90; CFI > .950; TLI > .950; and RMSEA < .08, respectively.

## RESULT AND DISCUSSION

### **The result of confirmatory factor analysis for Organizational Citizenship Behavior**

Confirmatory analysis or often also called confirmatory factor analysis (CFA) was designed to test the multi dimensions of a theoretical construct. This analysis is often also called test validity of theoretical constructs. The CFA employee to test the goodness of fit and tests of significance weighing factors. Variables of organizational citizenship behavior (OCB) consists of six (6) item statement. Each statement is based on indicators OCB developed according to the theory. Confirmatory factor analysis as a benchmark measurement model (measurement model) used in organizational citizenship behavior variables as shown in Figure 1.

Figure 1. Confirmatory Factor Analysis of Organizational Citizenship Behavior

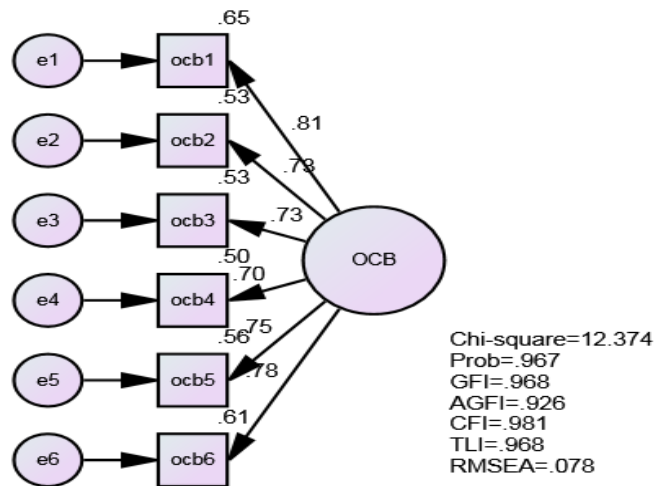

Results of testing the suitability of the model in the confirmatory factor analysis is to demonstrate the  $X^2$  test of OCB of 9.715. Furthermore, probability value of  $0.967 > 0.05$ ; GFI of  $0.968 > 0.90$ ; AGFI of  $0.926 > 0.90$ ; CFI of  $0.981 > 0.950$ ; TLI of  $0.968 > 0.950$  and RMSEA of  $0.061 < 0.078$ . Referring to the goodness of fit index means that the model is expressed well. Eligibility index is within the range of expected values or be in a good criterion so that this model can be accepted. Figure 1 above also shows the value of the loading factor of each item statement is used to measure the variables of OCB is greater than 0.70. This means that all items related to the statement construct organizational citizenship behavior is valid to measure these variables.

### The result of confirmatory factor analysis for Social Capital

The Variable of social capital consists of 9 item statement. Each statement is based on indicators of social capital based on the related literature and previous empirical research. Confirmatory factor analysis as a benchmark measurement model are used in social capital variables as shown in Figure 2.

Figure 2. The Result of Confirmatory Factor Analysis for Social Capital

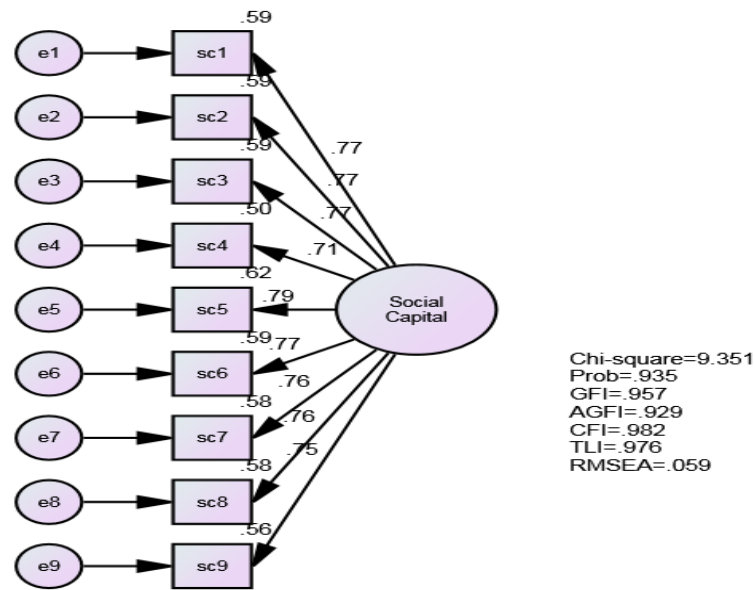

Results of testing the suitability of the model in the confirmatory factor analysis to demonstrate the value of  $X^2$  test of 9.351. Furthermore, probability value of  $0.935 > 0.05$ ; GFI of  $0.957 > 0.90$ ; AGFI of  $0.929 > 0.90$ ; CFI of  $0.982 > 0.950$ ; TLI of  $0.976 > 0.950$  and RMSEA of  $0.059 < 0.078$ . Referring to the suitability index value means that the model is expressed well. Eligibility index is within the range of expected values or be in a good criterion so that this model can be accepted. Factor loading value of each item statement is used to measure the variables of OCB is greater than 0.70. This means that all items are the statements related to the social capital constructs declaring the validity to measure the variables

### **The analysis of social capital and organizational citizenship behavior relationships**

In line with the purpose of research which analyzed the relationship between social capital and OCB, using structural equation models (SEM) as tools of data analysis it has been known that there is positively and significantly relationship between social capital and OCB. This is indicated by the output section SEM in figure 3.

Figure 3. Output AMOS Describes the Social Capital and OCB Relationships



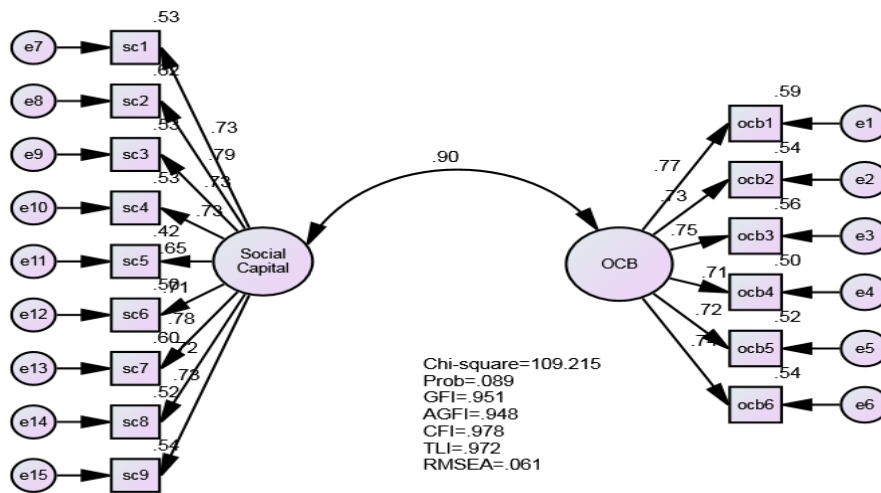

Goodness-of-fit index shows the chi-square test of 109.215 is smaller when it is compared with chi-square table 123.225. Furthermore, probability value of  $0.089 > 0.05$ ; GFI of  $0.951 > 0.90$ ; AGFI of  $0.948 > 0.90$ ; CFI of  $0.978 > 0.950$ ; TLI of  $0.972 > 0.950$  and RMSEA of  $0.061 < 0.08$ . Referring to the Goodness-of-fit index means that the model is good. The results showed that OCB is positively and significantly related to the social capitals of parliament member of Aceh province Indonesia. The better the social capital that is owned by legislators the better the OCB of the parliament member. Whereas the lower the social capital, the lower the organizational citizenship behavior. This implies that the organizational citizenship behavior of legislators is strongly associated with social capital that exists with the legislators.

Social capital in the member of Parliament is reflected in some indicators including concerns for fellow colleagues, has a good relationship with colleagues, have good social relations with the community, believing local governments, co-workers and have a good relationship with all parties concerned with the legislature. Finally, social capital can also be seen legislators of their care and concern for the community. The better the social capital of legislators as measured by these indicators, the better their organizational citizenship. This is reflected in the willingness to help colleagues, encouraging coworkers to work harder, to prevent problems in the work, accept the working conditions which are less than ideal, to initiate improving performance and keep the rules which have been set in the legislature.

Members of parliament who have a high concern to the community are more likely tend to improve their performance. In addition, the members are also working to prevent problems in carrying out their duties, especially in terms of its legislative function, budgeting and supervision. They also encourage their colleagues to be able to work harder for the sake of society. Instead, legislators with relatively low social capital are characterized by a lack of social relationships with the community and the work environment, less concerned about the efforts to improve their performance. In addition, they are included in this group are also less earnestly carry out their work, especially in carrying out the functions of legislation and monitoring functions. The existence of significant and positive relationship between social capital and OCB in line with research findings by Shahi et al. (2013); Yazdanpanah & Pordal (2014) which concluded that the social capital significantly related to citizenship behavior. The study's findings also support research findings Amintojjar et al. (2015) which provides an emperical evidence that OCB related to social capital directly..

## **CONCLUSION AND SUGGESTION**

### **Conclusion**

This paper analyzes the relationship between social capital and OCB among legislators in the Aceh province of Indonesia. With the samples of 243 members of parliament, it was found that social capital has a very close relationship with OCB. The better the social capital, the better the OCB. It can be concluded that social capital is an important determinant of OCB embodied in the attitudes and behavior of legislators in the legislature.

### **Suggestion**

Efforts to improve OCB among members of parliament is extremely important. In terms of their duties and functions as representatives of the people, every member of Parliament is required to cooperate with one another. Especially in carrying out tasks in supervision and budgeting. Cooperation occurs certainly not only with a fellow member of Parliament but also with executives such as chief of local government unit both at the district and at the province. Social capital which is owned by a legislator was able to improve organizational citizenship behavior so that they work better. Therefore, the strategic policy that must be done by the local government in Aceh is to increase the social capital of the legislative members.

### **Implication for Future Research**

Future research should examine the relationship between social capital and OCB by inserting variable demographic characteristics as moderating variable between these two variables. It is based on the premise that the demographic characteristics can also shape the behavior of individuals, including members of the legislature.

### **ACKNOWLEDGMENT**

This paper is a research outcome in collaboration with my best friend, a lecturer at the economic faculty of Muhamadiyah University, Aceh. For Nurmala, I wish you rest and peace in heaven.

### **REFERENCES**

- Abdollahi, S & Gorji, M. (2014). The relationship between social capital and organizational citizenship behavior in universities, *Advanced Research in Economic and Management Sciences*, 17, 68-75.
- Ahmadpoor, R., Yektayar, M., & Nazari, R. (2014). Structural equation modeling of relationship between organizational citizenship behavior and social capital with organizational learning among physical education teachers, *European Journal of Sports and Exercise Science*, 3(2), 39-44.
- Aldag, R., & Reschke, W. (2007). *Employee Value Added: Measuring Discretionary Effort and Its Value to the Organization Center for Organization Effectiveness Inc. USA. London.*
- Amintojjar, H., Shekari, G. A., & Zahibi, M. R. (2015). The effect of social capital on organizational citizenship behavior: A case study of employees in Mashhad Municipality, *International Journal of Organizational Leadership*, 4, 144-153.

- Amri, K. (2013). Faktor-faktor Yang Mempengaruhi Loyalitas Konsumen Surat Kabar Harian Serambi Indonesia di Kota Banda Aceh, *Jurnal Ekonomi Manajemen dan Bisnis* 1(1), 229-242.
- Amri, K. (2015). Pengaruh Perilaku Kepemimpinan dan Motivasi Dalam Meningkatkan Produktivitas Kerja Karyawan PT Bank Sinarmas Tbk Cabang Banda Aceh, *Jurnal Ekonomi Manajemen dan Bisnis*3(1), 522-536
- Archana, S., & Unni, V. (2014). A Study of Relationship between Social Capital and Organizational Citizenship Behavior, *International Journal of Managerial Studies and Research*, 2(4), 76-81.
- Ariani, D. W. (2012). The Relationship between social capital, organizational citizenship behaviors, and individual performance: An empirical study from banking industry in Indonesia, *Journal of Management Research*, 4(2), 226-241.
- Baghersalimi, S., Reza, H., Keldbari R., & Alipour, H. R. (2011). Organizational Citizenship Behavior And Employees Social Capital Case Study Rasht Hospitals, *Australian Journal of Basic and Applied Sciences*, 5(8), 1185-1193.
- Balino, M. C., Turnley, W. H., & Bloodgod, J. M. (2002). Citizenship Behavior and The Creation Of Social Capital in Organizations, *Academy of Management Review*, 27(4), 505-522.
- Bogler, R., & Somech, A. (2005). Organizational citizenship behavior in school: How does it relate to participation in decision making. *Journal of Educational Administration*, 43(5), 420-438.
- Farnita, I., & Amri, K. (2013). Persepsi Mahasiswa Terhadap Kualitas Layanan Pendidikan Akademi Manajemen Informatika dan Komputer Indonesia (AMIKI) Banda Aceh, *Jurnal Ekonomi Manajemen dan Bisnis* 1(1), 118-139.
- Iskandar, D., & Amri, K. (2013). Pengaruh Daya Tarik Iklan, Kualitas Pesan Iklan dan Frekuensi Penayangan Iklan Terhadap Efektifitas Iklan Televisi Produk Mie Instan Merek Indomie Goreng Cabe Ijo, *Jurnal Ekonomi Manajemen dan Bisnis*, 2 (2), 424-437.
- Jahangir, N., Akbar, M. M., & Haq, M. (2004). Organizational citizenship behavior: Its nature and antecedent. *BRAC University Journal*, 1(2), 75-85.
- Jex, S. M. (2002). *Organizational psychology a scientist-practitioner approach*. New York: John Wiley & Sons.
- Moghimi, S. M. (2010). The effect of social capital on organizational excellence. *Strategic Management Studies*. 3, 123-143.
- Nahapiet, J., & Ghoshal, S. (1998). Social capital, intellectual capital, and the organizational advantage. *Academy of Management Review*, 23, 242-266.
- Organ, D. W., & Ryan, K. (1995). A meta-analytic review of attitudinal and dispositional predictors of organizational citizenship behavior. *Personnel Psychology*, 48(4), 775-803.

- Organ, D. W., Podsakof, P. M., & Mackenzie, S. B. (2006). *Organizational citizenship behavior: Its nature, antecedents, and consequences*. California: Sage Publication.
- Piercy, N.F., N. Lane, & D.W. Cravens.(2002). A gender perspective on sales person organizational citizenship behaviour, sales manager control strategy and sales unit effectiveness, *Women in Management Review*, 17(8): 373-391.
- Putnam, R. D. (1993). *Making democracy work: Civic traditions in modern Italy*. Princeton, NJ: Princeton University Press.
- Randall, D. M. (2000). The consequences of organizational commitment: Methodological investigation. *Journal of Organizational Behavior*, 11, 361-378.
- Ratnawati., & Amri, K. (2013). Pengaruh Keadilan Organisasional, Kepercayaan Pada Atasan Terhadap Perilaku Kewargaan Organisasi (*Organizational Citizenship Behavior*), *Jurnal Ekonomi Manajemen dan Bisnis* 1(1), 56-73.
- Sabatini, F. (2008). Does social capital improve labor productivity in Small and Medium Enterprises?. *International Journal of Management and Decision Making*, 9(5), 452-480.
- Shahi, A., Alipour, H., & Feizi, M. (2013). Examining the relative importance of social capital dimensions on citizenship behaviors of Moghan's agro industry company employees, *Arabian Journal of Business and Management Review*, 2(7), 64-71.
- Yazdanpanah, R., & Pordal, A. (2014). The relationship between social capital and organizational citizenship behaviour (Case study: Yasouj education and training), *Indian Journal of Fundamental and Applied Life Sciences*, 4(4), 2092-2099.

Halaman ini sengaja dikosongkan  
*(this page intentionally left blank)*